

# Model ACF

## Adjustable Crane Fork

-The Adjustable Crane Fork converts an overhead crane into a maintenance-free low cost fork lift that can handle various widths and includes multiple lifting positions to ensure a level pick regardless of load size.

-External weld reinforcing plates strengthen both the weld and tube at critical stress areas.

-Each lifter is proof tested exceeding ANSI/ASME B30.20 standards and a test certificate is issued. Each unit is painted safety yellow and clearly marked on both sides with rated capacity to conform to OSHA standards.

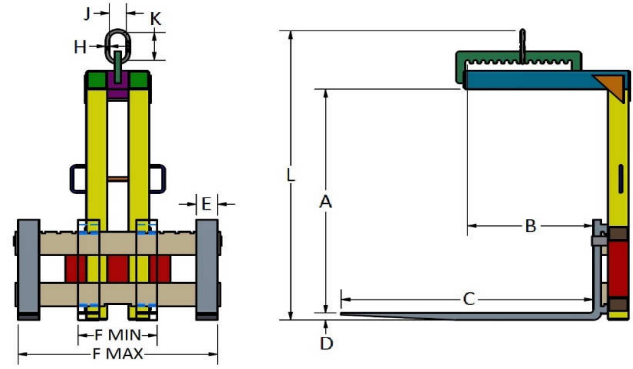

Capacity	Vertical Clearance	Dist. To Center of Gravity	Fork Length	Fork Size		Outside Width F		Lift Ring Size			Total Height	Approx. Unit Weight	Model Number
	A	B	C	D	E	Min.	Max.	H	J	K	L		
Pounds	Inches											Pounds	
2000	48	24	48	1-1/4	4	15	36	0.63	2.80	5.00	60-1/2	485	ACF - 02
4000	48	24	48	1-1/2	4	15	38	0.73	3.20	6.00	61-5/8	610	ACF - 04
6000	48	24	48	1-3/4	4	15	38	0.88	3.75	6.38	63-4/8	730	ACF - 06
8000	48	24	48	1-3/4	5	18	42	1.10	4.30	7.50	66-1/4	1090	ACF - 08
10000	48	24	48	2	5	18	42	1.10	4.30	7.50	68-1/2	1230	ACF - 10
15000	48	24	48	2-1/4	6	21	48	1.33	5.50	9.50	70-1/4	1600	ACF - 15
20000	48	24	48	2-1/2	6	21	48	1.61	5.90	10.50	70-1/4	1810	ACF - 20

# Model FCF

## Fixed Crane Fork

-The Fixed Crane Fork converts an overhead crane into a maintenance-free, low cost fork lift that includes multiple lifting positions to ensure a level pick regardless of load size.

-External weld reinforcing plates strengthen both the weld and tube at critical stress areas.

-Each lifter is proof tested exceeding ANSI/ASME B30.20 standards and a test certificate is issued. Each unit is painted safety yellow and clearly marked on both sides with rated capacity to conform to OSHA standards.

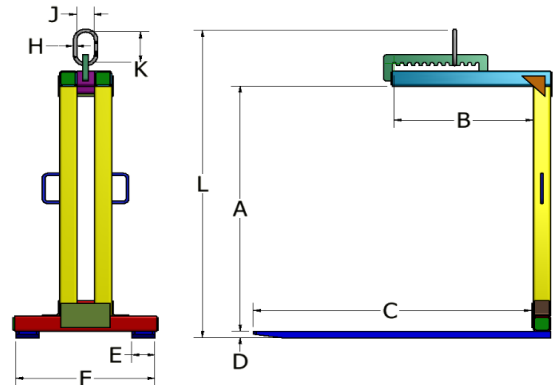

Capacity	Vertical Clearance	Dist. To Center of Gravity	Fork Length	Fork Size		Outside Width	Lift Ring Size			Total Height	Approx. Unit Weight	Model Number	
	A	B	C	D	E	F	H	J	K	L			
Pounds	Inches											Pounds	
2000	48	24	48	1-1/4	4	24	0.63	2.80	5.00	61-1/2	339	FCF - 02	
4000	48	24	48	1-3/4	4	24	0.63	2.80	5.00	62-5/8	423	FCF - 04	
6000	48	24	48	1-3/4	4	28	0.88	3.75	6.38	65-1/4	585	FCF - 06	
8000	48	24	48	1-3/4	6	36	1.10	4.30	7.50	66-1/4	715	FCF - 08	
10000	48	24	48	2-1/4	6	38	1.10	4.30	7.50	69-1/4	810	FCF - 10	
15000	48	24	48	2-1/2	6	42	1.33	5.50	9.50	71-5/8	1050	FCF - 15	
20000	48	24	48	3	6	54	1.61	5.90	10.50	75-3/4	1489	FCF - 20	

- Notes:
1. Fork length is equal to the maximum load length
  2. All loads must be centered under lifting ring.
  3. Please verify that the lift ring size will suit the crane hook.
  4. Custom capacities and load lengths available upon request.



PLEASE NOTE: WEIGHT AND DIMENSIONS MAY VARY AND ARE PROVIDED FOR REFERENCE ONLY. SPECIFIC WEIGHT CANNOT BE DETERMINED UNTIL THE UNIT IS FABRICATED.

PHONE 855.800.9568 - FAX 716-667-6837  
 EMAIL: [webinfo@eltlift.com](mailto:webinfo@eltlift.com)  
 WEB: [www.eltlift.com](http://www.eltlift.com)